



- Built to Customer Specifications
- Temperatures range -60F to 160F
- Up to four SPDT Snap Acting Switches
- Optional NEMA 1 housing



GENERAL DESCRIPTION

The series 6PS density switches are rugged temperature compensated pressure switches designed for use on:

- High Voltage Circuit Breakers.
- Gas Insulated Substations.
- Gas Insulated Bus Systems.

Bi-metal disks provide the temperature compensation to the switching mechanism over a wide temperature range. This temperature compensation feature allows the pressure switch to ignore pressure changes of the gas due to changing temperature and operate only when a loss of gas is detected indicating a change in density. The switching mechanism is located on a rugged cast aluminum body. The unit has relatively few moving parts which adds to its accuracy and reliability. The mechanism assembly can operate two, three or four full size SPDT electric switches. All intrinsic temperature compensated switches must be mounted so that they change temperature at approximately the same rate as the gas.

All density switches are manufactured to customer specifications. Once installed, they require no maintenance or field calibration. Each device is factory tested at several temperatures that always include -40F. Solon has evolved the design of components used in these switches that can be combined to meet customer's requirements. This allows Solon to quickly develop new model variations to meet customer's changing specifications.

MODEL SERIES 6PS SF₆ Gas Density Switch Intrinsic Design

SPECIFICATIONS

Switching

2, 3, or 4 S.P.D.T. snap acting switches

Electrical Connection

Screw terminals standard

Pre-wired with 18" leads available

Switch Contact Ratings

15A; 125, 480 VAC / 6A res.; 28 VDC std.

Setpoint Adjustment

Factory set per customer specifications

Temperature Range

-60°F to 160°F Ambient Standard

Accuracy (Standard)

± 1.5 PSI at 70°F

± 3 PSI at temperatures of 140°F to -40°F

Higher accuracy devices are available

Deadband (Switch Differential)

Fixed; 1-6 PSI Typical (per Cust. requirements)

Pressure Sensing Element

Phosphor Bronze or Stainless Steel Bellows - 100% leak inspected with Helium mass spectrometry to 9×10^{-9} cc/sec.

Pressure Adjustment Range

Phosphor Bronze Bellows: 5-100 PSI; 150 PSI max.

Stainless Stl. Bellows: 5-100 PSI; 300 PSI max.

150-500 PSI; 1000 PSI max.

Pressure Port

¼ NPTF or 7/16-20 SAE are standard; Other port options are available.

Enclosure (optional)

NEMA 1 design

Base material 356 cast aluminum

Cover material cast aluminum

Weight

Approximately 3 lbs (1.4 kg).

Solon Manufacturing Company

425 Center Street, P.O. Box 207, Chardon, Ohio 44024

(440) 286-7149 800-323-9717 FAX (440) 286-9047

Email: solon@solonmfg.com

SWITCH DIMENSIONS

MODEL SERIES 6PS SF₆ Gas Density Switch Intrinsic Design

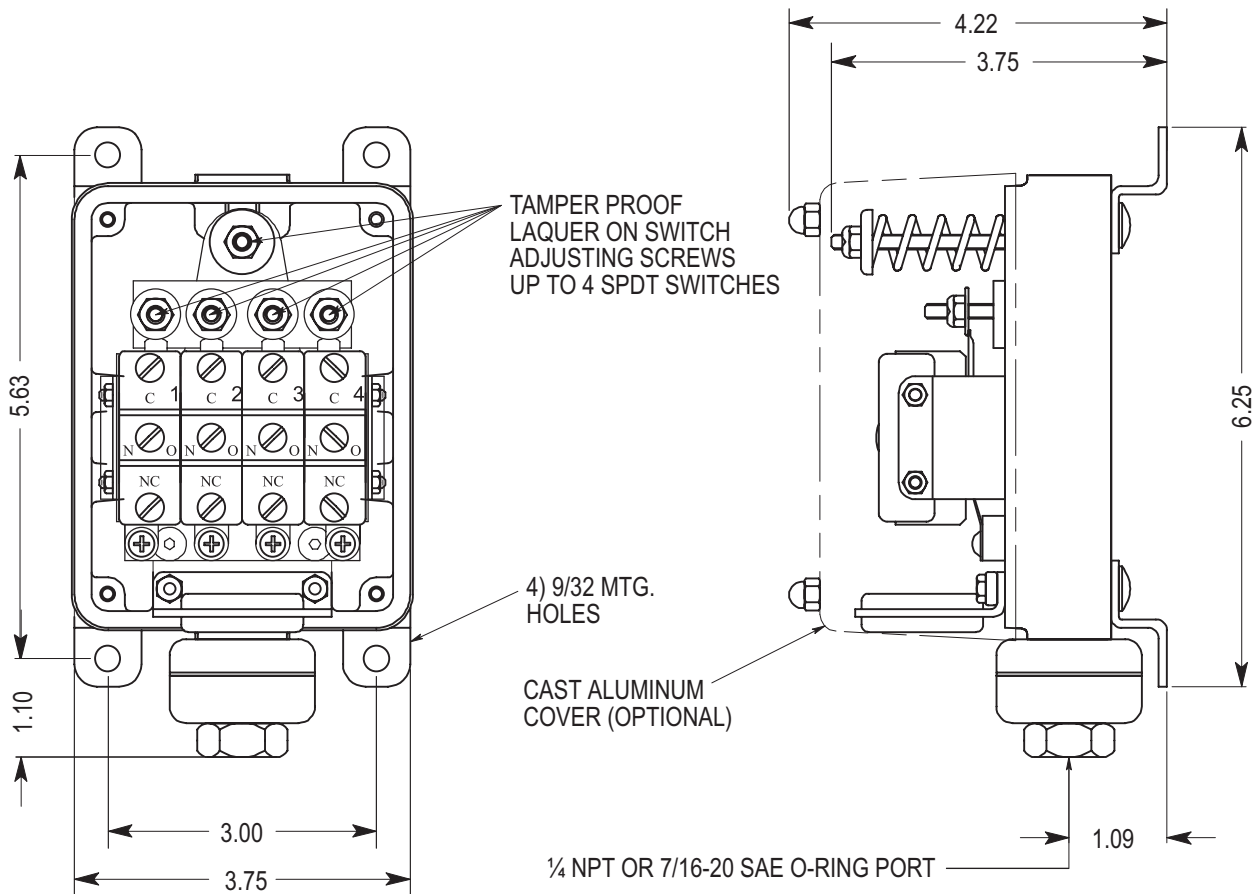

Wiring Schematic

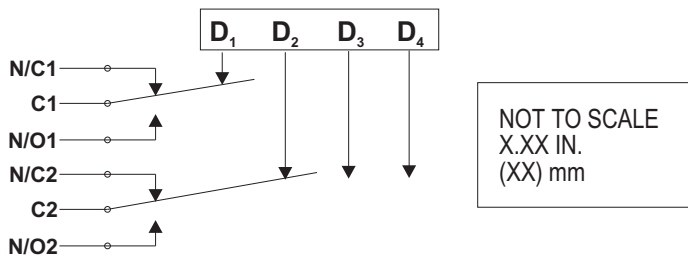

SPECIFYING A SWITCH

1. Specify the set points for each switch. Set points should be given at room temperature (68F) and at either of the temperature extremes.
2. Designate the pressure port fitting.
3. Choose the type of electrical connection;
 - * Screw terminals or,
 - * Prewired - Color coded 18 GA. MTW, 18" Lg.
4. Describe other requirements such as special testing, labeling, tagging, packaging, etc.
5. Once a switch is specified and an order is placed, Solon Mfg. Co. will assign a "slant number" (6PS/XXX) to the switch. This ensures that the fit, form, and function of the device will not change.

INSTALLATION NOTES

Orientation - The 6PS will operate satisfactorily in any position.

Location - The switch body should be installed where it will follow the temperature of the SF₆ gas (out of direct sunlight and away from any heating elements.)

Wiring - No. 6 screw terminals are standard. Switches may be wired to 'normally open' or 'normally closed' terminals of the switch contacts. Always connect positive to the common terminal. Care should be taken so that wires do not contact the mechanism or spring.

Piping - Always use a wrench to hold the pressure port while the fitting is tightened (do not over-tighten). Thread sealant should always be used on NPT threads.

Checking Calibration - First, obtain a pressure vs. temp. curve. Second, accurately record the temperature of the switch body. Third, lower pressure slowly and record set points. Make certain that there is a load (8V or 150 mA min) on the switch. Finally, compare settings to the graph. **DO NOT ADJUST SETTINGS IN THE FIELD.**

SOLON 
800-323-9717